

GOODTOOL

Brake Service Tools and Supplies

1-800-880-7121

www.goodtool-online.com

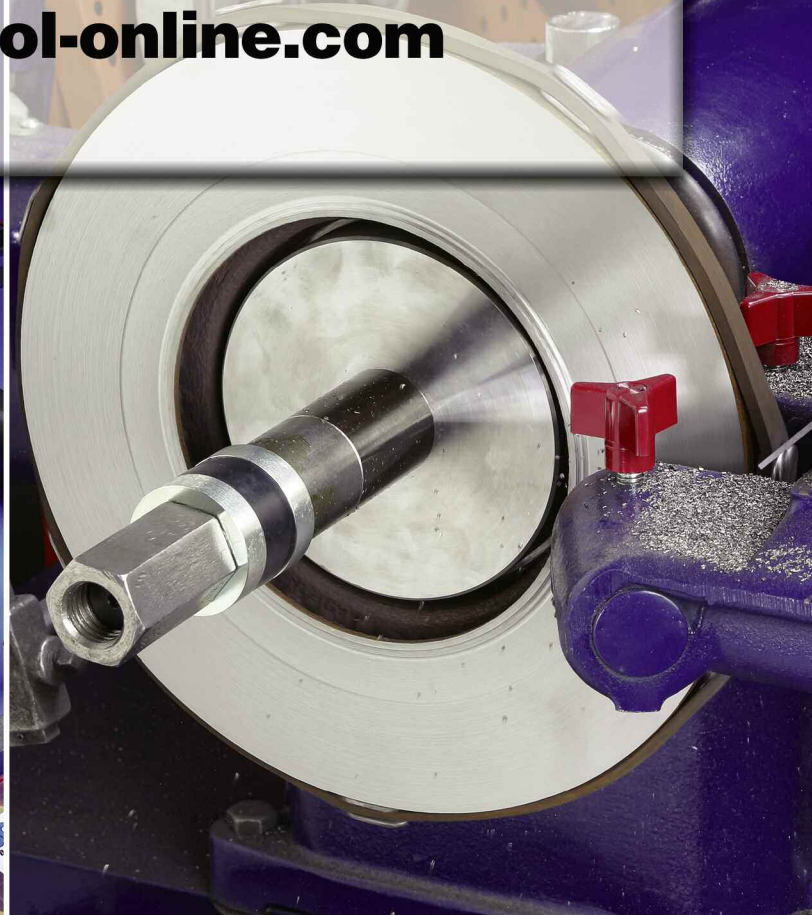

Tips shown actual size

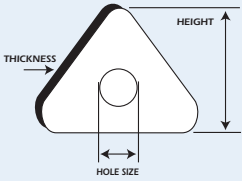
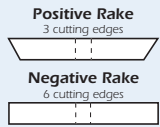
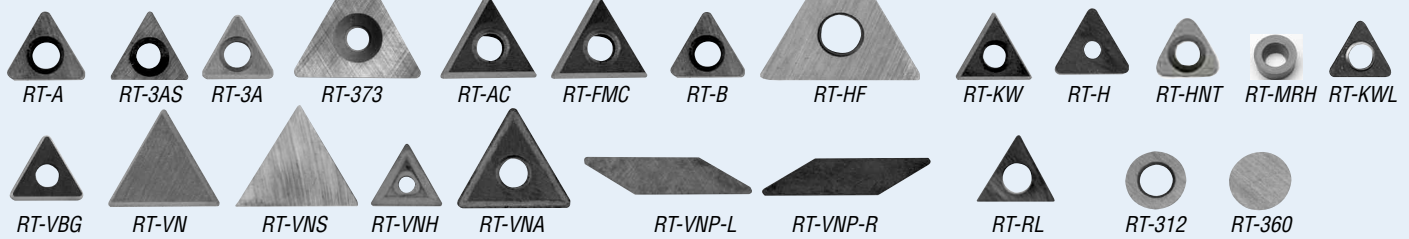

Round cutting tips yield as many as 20 cutting edges per tip

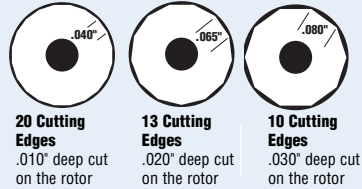

Solid Carbide

These standard grade, solid carbide cutting tips are parallel ground for resurfacing cast iron drums and rotors.

Honed-edge Carbide

These solid carbide cutting tips are parallel and peripheral ground. Honed edges deliver a better finish on cast iron and composite rotors. Best for rusty surfaces.

Titanium

Premium grade titanium coated carbide cutting tips are parallel, peripheral ground for ultimate performance and finish on cast iron and composite rotors. **NOTE:** Will not work well on rusty rotor and surfaces.

Buy in bulk and SAVE!

Order 3 or more packs, **save 10%**

Order 10 or more packs, **save 20%** Tips also sold individually

Machine	Model(s)	OE No.	Edges	Rake	Screw Incl.	10 Pk. Price	Order No.	10 Pk. Price	Order No.	10 Pk. Price	Order No.
Ammco	700, 705, 710, 1000, 2002, 3000, 3860	6914	6	Neg	✓		RT-A		RT-A-H		RT-A-T
	4000, 4100, 7000, 7500, 7700										
	800, 3850	6918	3	Pos	✓		RT-3AS		RT-3AS-H		RT-3AS-T
Twin Cutters:	6900, 6950	6914	6	Neg	✓		RT-A		RT-A-H		RT-A-T
		6918	3	Pos	✓		RT-3AS		RT-3AS-H		RT-3AS-T
		7681	3	Pos	✓		RT-3A		RT-3A-H		RT-3A-T
	7900	6914	6	Neg	✓		RT-A		RT-A-H		RT-A-T
Ammco HD	5000, 6000, 6002	5677	3	Pos	✓		RT-373				
Accu-Turn	All combination Disc/Drum Lathes	433796	3	Pos	✓		RT-AC		RT-AC-H		RT-AC-T
	On-The-Car Lathes	878051	6	Neg	✓		RT-A		RT-A-H		RT-A-T
All-Tool	747, 777	3331	6	Neg	✓		RT-A		RT-A-H		RT-A-T
Bean	B-401, B-410, B-501, B-601	90487, 90488	3	Pos	✓		RT-FMC		RT-FMC-H		RT-FMC-T
Bear	1410, 1466, 1467, 1468, 1469, 1478	2264, 72265 772 834	6	Neg	✓		RT-B		RT-B-H		
	10-1430, 10-1435	W136	6	Neg			RT-HF				RT-HF-T
FMC	600, 601, 700, 701, RotoTruer	90487, 90488	3	Pos	✓		RT-FMC		RT-FMC-H		RT-FMC-T
	505, On-The-Car Lathe	91212	3	Pos	✓		RT-KW		RT-KW-H		RT-KW-T
Hoffman	660, Coats CLB-10	3331	6	Neg	✓		RT-A		RT-A-H		RT-A-T
Horvath	All	1605	6	Neg			RT-H				
Hunter	BL300 On-The-Car Lathe	221580-2	6	Neg	✓		RT-A		RT-A-H		RT-A-T
	BL-500, BL-501, BL-505	6918	3	Pos	✓		RT-3AS		RT-3AS-H		RT-3AS-T
	BL-500	221-678-3	3	Pos			RT-HNT				
	Micro Tips for OCL-400 Lathes	221-626-3			✓		RT-MRH				
Kwik-Way	CBL,NCL,SDL, 108 OTC, Kwik-Lathe On-The-Car	109-1092-23	3	Pos	✓		RT-KW		RT-KW-H		RT-KW-T
	Lightening Lathe	109-1092-45	3	Pos	✓						RT-KWL-T
Performance	6600,7200,7100, 7600	3331	6	Neg	✓		RT-A		RT-A-H		RT-A-T
Pro-Cut	On-The-Car Lathe	50-701, 50-742	3	Pos	✓		RT-VBG		RT-VBG-H		RT-VBG-T
RJ West	915D Disc Lathes	W136	6	Neg			RT-HF				RT-HF-T
	Perfect 400, 1115HD, 1215 True Cut	W139	3	Pos	✓		RT-AC		RT-AC-H		RT-AC-T
RTI	BRC35 On-The-Car Lathe	91212	3	Pos	✓		RT-3A		RT-3A-H		RT-3A-T
Snap-On	YA282, YA277, YA278, YA180 On-The-Car Lathe	109-1092-23	3	Pos	✓		RT-KW		RT-KW-H		RT-KW-T
Van	204, 204D, 205, 205DC, 415, 234XV	29687	3	Pos	n/a		RT-VN		RT-VN-H		RT-VN-T
Norman and Rels	Smaller (1/64") radius		3	Pos	n/a		RT-VNS		RT-VNS-H		RT-VNS-T
	Older Model 204	21933	6	Neg			RT-VNH				
	204, 304, 405	29005	6	Neg			RT-VNA				RT-VNA-T
	303,304,305,404,405,V22	304-7167	2	Pos	n/a		RT-VNP-L				RT-VNP-LT
	204,205,205DR,300, 302,333,243,243XV	302-7167	2	Pos	n/a		RT-VNP-R				RT-VNP-RT
	Rels 2000 rotor	45016, 45021	3	Pos	✓		RT-RL				
VBG	On-The-Car Lathe	50-701, 50-742	3	Pos	✓		RT-VBG		RT-VBG-H		RT-VBG-T
Round Tips with hole	Fits TAM-312 and TFM-312 Holders	RT-312,RT-312T	360°	Pos	✓		RT-312				RT-312T
	without hole	Fits TAM-360SET, TFM-360SET, RJH and CT Holders	CT10	360°	Pos	n/a	RT-360				RT-360T

NOTE: The table above shows the original-equipment cutting tips for Ammco machines. Most of them use negative-rake tool systems. However, some Ammco machines (especially the 4000 and 7000-series) have been modified in the field by using the TAM-25968 and TAM-25969 positive-rake tool holders (see next page). If your machine is shown above to have 6-edge tips but has 3-edge tips, it has been modified – please order our RT-3A or RT-3AS series tips.



Tip Holders for Turning Drums

Positive Rake Holders for Ammco Drum Lathes

- Measures 1/2" x 3/8" x 1 1/16"
- Includes 1 RT-3A Positive Rake Tip • Fits Ammco 1000, 2002, 3000, 4000, 4100 & 7700 lathes
- Order No. **TAM-7970**



.235" Dia. Round Micro Cutting Tips & Holders For Hunter

OCL-400 Lathe

Description	Order No.
Micro-Tip (1)	RT-MRH-E
#7 Torx Head Screw	RT-MRH-SCREW
Micro Tip Set (10 tips, 4 screws)	RT-MRH
Tip & Holder Set (2 holders, 2 tips & 2 screws)	RT-MRH-SET
Torx Wrench	SCW-T7

Brake Tip Combo Packs

For Ammco & Accu-Turn

- 10 tips (6-round, 4-triangular)



Application	Order No.
Ammco	RT-64A
Accu-Turn	RT-64AC

Brake Lathe Tip Holders

Machine	Model	Use	OE No.	Order No.
Ammco	1000, 2002, 3000, 4000, 4100, 7700	For Drums 1/2" x 3/8" x 2 1/4"	9872	TAM-41R
All-Tool	747	Use: RT-A series,		
Hoffman	660	negative rake tips		
Performance	6600, 7200, 7100, 7600			
Ammco	3000, 3850, 4000, 4100, 7000 & 6900, 6950 Twin Cutters	For Rotors 3/8" x 3/8" x 1 7/8"	10701	TAM-701 (R)
Performance	6600, 7200, 7100, 7600	Use: RT-A series,	10702	TAM-702 (L)
Hoffman	660	negative rake tips		
All-Tool	747			
Ammco	3000, 3850, 4000, 4100, 7000 & 6900, 6950 Twin Cutters	For Rotors 3/8" x 3/8" x 1 7/8"	25968	TAM-25968 (R)
		Use: RT-3A & RT-3AS series,	25969	TAM-25969 (L)
		positive rake tips		
Ammco	3850	For Drums 3/8" x 3/8" x 2 1/16"	5390	TAM-5390
		Use: RT-3A & RT-3AS series,		
		positive rake tips		
Ammco	2002, 3000, 4000, 4100, 7700	Small Drum Tool 3/4" x 9/16" x 5"	5392	TAM-5392
		Use: RT-3A series,		
		positive rake tips		
Ammco	7692 right angle holder (Replaces Ammco Duplex Tool Bit)	Uses: RT-A series,	7692	TAM-7692
		negative rake tips		
		For Flywheels 3/8" x 3/8" x 1 7/8"		
Ammco	1000, 7900 Twin Cutter	For Drums/Rotors 1" x 1 3/8" x 2"	25762	TAM-25762 (LH)
		Use: RT-A series, negative rake tips		TAM-25761 (RH)
		(Left Hand Holder Shown)		
Ammco HD	5000, 6000, 6002	For Drums 5/8" x 5/8" x 4"	9695	TAM-9695
		Use: RT-373,		
		positive rake tips		
Ammco HD	5000, 6000, 6002	For Rotors 5/8" x 5/8" x 4 1/2"	5878	TAM-5878
		double-ended (use 2)		
		Use: RT-373, positive rake tips		
Hunter	BL500	Positive rake 1/2" x 1/2" x 2"	2221-677-2	THNT-677 (R)
				THNT-676 (L)
Accu-Turn	fits all combination lathes	Drums & Rotors 3/8" x 3/8" x 2 3/4"	433763	TFM-42R (R)
FMC	600, 601, 700, 701, RotoTruer	Use: RT-AC & RT-FMC series,	433764	TFM-42L (L)
Hoffman	Perfect 400	positive rake tips		
Bear	1410, 1466, 1467, 1468, 1469, 14781	Drums and Rotors 3/8" x 3/8" x 3"	90495	TBR-44R (R)
		Use: RT-B series,	90494	TBR-44L (L)
		negative rake tips		
Kwik-Way	CBL, NCL, SDL	3/8" x 3/8" x 2 1/2"	109-1091-00	TKW-84R (R)
Snap-On	Y282, Y277, Y278 & 180	Use: RT-KW series,	109-1091-02	TKW-85L (L)
		positive rake tips		
Kwik-Way	CBL, NCL, SDL	3/8" x 3/8" x 1 3/4"	108-1009-07	TKW-86R (RH)
Snap-On	Y282, Y277, Y278 & 180	Use RT-KW series,	108-1010-08	TKW-87L (LH)
		positive rake		
Accu-Turn, FMC, Ammco, KW	For Curved Rotors with a flange	For Rotors 3/8" x 3/8" x 3"	434057	TFO-42R (R)
		Use: RT-FMC series,	434056	TFO-42L (L)
		positive rake tips		
Ammco	Direction: Left	3/8" x 3/8" x 1 7/8"		TAM-312L
Hoffman	Direction: Right	3/8" x 3/8" x 1 7/8"		TAM-312R
Performance, All-Tool		Use: RT-312 series tips		
Accu-turn	Direction: Left	3/8" x 3/8" x 2 3/4"		TFM-312L
FMC Bear,	Direction: Right	3/8" x 3/8" x 2 3/4"		TFM-312R
Hoffman, Kwik-Way, Snap-On, etc.		Use: RT-312 series tips		
Hunter	Set of holders & tips (1 of each)	Use RT-MRH tips		RT-MRH-SET

Double Duty Cutting Tip Holders

- Round tip holder on one end, standard triangle tip holder on the other

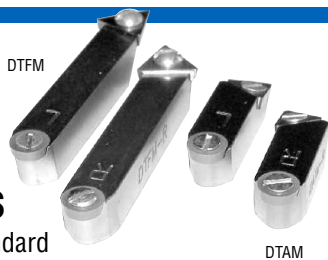

Application	Order No.	Incl.
Ammco, All-Tool, Hoffman, Performance	DTAM-SET	▼
FMC, Accu-Turn, Hoffman, Kwik-Way, VanNorman	DTFM-SET	▼
Application	Size	
Ammco	3/8" x 3/8" x 1 3/16"	Left DTAM-312L 1
Hoffman, Performance, All-Tool		Right DTAM-312R 1
FMC, Accu-Turn, Hoffman 400	3/8" x 3/8" x 2 3/4"	Left DTFM-312L 1
Kwik-Way, Van Norman		Right DTFM-312R 1
Ammco Tips (6-RT-312T, 4-RT-A)		RT-64A 1
Accu-turn Tips (6-RT-312T, 4-RT-AC)		RT-64AC 1

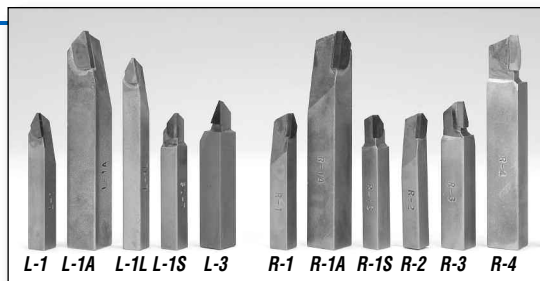

Brazed Carbide Brake Lathe Tools Fit most popular brake drum lathes

Left Hand Cutting Tools			
Size	Application	Price	Order No.
3/8" sq. x 2 1/2"	Replaces Bean 43-46L; Bear 23211; Star CB-8; VN 302-7272 for 303, 304, 304H		L-1
5/8" sq. x 4"	Replaces Ammco 5725, for 5000; Star CB-30; VN "Big Brute" for 310-404 Hardspots		L-1A
3/8" sq. x 3 1/2"	Extra long L-1 for small dia. drums		L-1L
3/8" sq. x 2 1/2"	Master carbide-tipped with 7° rake angle		L-1S
1/2" sq. x 2 3/4"	Replaces Ammco 4726 heavy-duty tool Ammco 4726 for 5000 & 6000 dual facing tool & 3000, 4000, 4100 & 7700 lathes		L-3

Right Hand Cutting Tools			
Size	Application	Price	Order No.
3/8" sq. x 2 1/2"	Replaces Bean 43-46R; Bear 20718; Star LB-18 VN 302-7171 for 204, 300,302, 302H, 333, 243XV; and Barrett & Lempco		R-1
5/8" sq. x 4"	Replaces Ammco 5720 for 5000; Lempco SHD, DH, 530 Kwik-Way Heavy Duty		R-1A
3/8" sq. x 2 1/2"	Master carbide-tipped with 7° rake angle		R-1S
3/8" sq. x 2 1/2"	Same as R-1, but for heavy-duty use For steel		R-2
1/2" sq. x 2 3/4"	Replaces Ammco 4725 for 3000, 4000, 4100, 7100 drum lathes		R-3
5/8" sq. x 4"	Replaces Bear 24034; Star CB-35		R-4

Hardspot Cutters

Left Hand		
Size	Use	Order No.
3/8" x 1/2" x 2 3/8"	Drums	L-5
	Discs	L-6
Right Hand		
Size	Use	Order No.
3/8" x 3/8" x 2 3/8"	Drums	R-5
	Discs	R-6

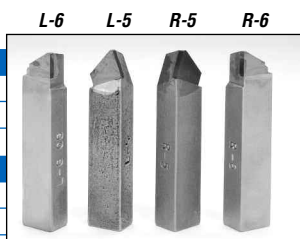

For the best surface finish, eliminate chatter when turning rotors & drums. Choose from the silencers below!



Silencers For Vented Rotors

Style	Size	OE No.	Order No.
Rubber Strap	34"L x 5/8"W x 3/16" thick	6920	CE-8
	36"L x 1 1/4"W x 3/16" thick	6930	CE-6930
Spring	Fits 6" to 9" rotors		CE-13
Rubber Tube	9" Diameter, 6 weights		CE-5
	8" Diameter, 4 weights		CE-5S

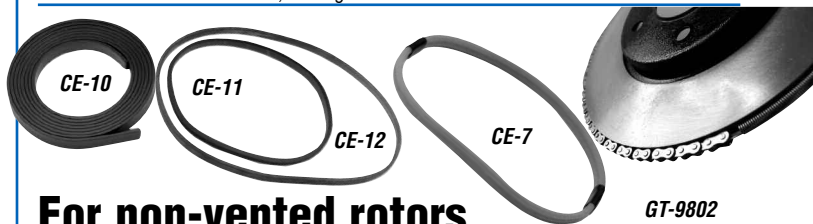

For non-vented rotors

Style	Size	Order No.
Magnetic Strap	48" long	CE-10
Rubber Band	6 1/2" dia. x 5/16" W x 3/16" thick	CE-11
	9 1/4" dia. x 5/16" W x 3/16" thick	CE-12
Rubber Tube	Fits 6" to 9" rotors	CE-7
Chain Band	Nickel plated with 4-springs	GT-9802

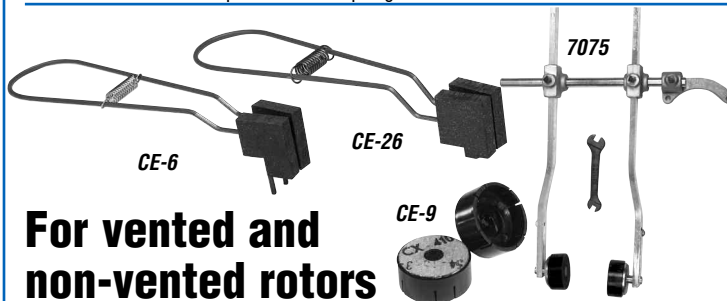

For vented and non-vented rotors

Style	Application	Order No.
Clamp-On	For Bench model lathes	CE-6
	For On-The-Car lathes	CE-26
Friction	Most Ammco lathes	7075
	Replacement Pucks for 7075	CE-9
	Replacement Mounting Bracket	GT-10283
	Replacement Wrench	GT-11497



For Drums

Style	Application	Order No.
Rubber Strap	Automobiles	5'L x 2 7/8"W x 1/8" thick CE-1
		5'L x 1 5/8"W x 1/4" thick CE-3
	Trucks	6'6"L x 2 7/8"W x 1/8" thick CE-2
		6'6"L x 1 5/8"W x 1/4" thick CE-4
Ammco Style	6'L x 1 3/4"W x 3/16" thick	CE-5280

Arbors & Accessories



GT-433701 GT-8542 GT-3101 1101 4101 GT-90043 GT-5389 GT-974222 GT-20442

Top-quality arbors meet or exceed OE specs

- Factory checked for runout of less than .001" • Heat treated, stress relieved tool steel • For drums and rotors up to 125 lbs. • Precision ground between centers using only one set-up for the greatest accuracy

1" Arbors

Machine	Model(s)	Thread	Order No.
Accu-Turn	7700, 8910, 8911, 8920, 8922, 8944, 8989, 8990, 8991, 8993, 8985 and 8997	1" x 8 LH	GT-433701
Hunter All Tool Performance	747		
Ammco	2002, 3000, 4000, 4100, 7000, 7500, 7700	7/8" x 9 LH	GT-3101
	1000	7/8" x 9 RH	1101
	3850	7/8" x 9 LH	4101
FMC/John Bean	600 & 700 Series	1" x 8 LH	GT-90043
Hoffman	201 Standard, 300, 350, 400, 401, 450 &	1" x 9 LH	GT-5389
RJ West	1115 HD Lathe		
Hunter	BL 501, BL-505	1" x 8 LH	GT-974222
VanNorman/Rels		1" x 8 LH	GT-20442
John Bean/FMC	800 series		

1" Arbor Accessories

Description	Model(s)	Thread	Order No.
Arbor Nuts	Fits all Ammco but 1101	7/8" x 9 LH	GT-3102
	Fits Ammco 1101 arbor	7/8" x 9 RH	25811
	All arbors above but Ammco	1" x 8 LH	GT-20442N
	Fits Hoffman 5389 only	1" x 9 LH	GT-5389N
Washer	for VN / Rels Arbor		GT-20442W
Centering Spring			GT-3110
1" Spacers	Length	Price	Order No.
for ALL Brake Lathes	1/2"		GT-3125
	1"		GT-5040
	1 1/2"		GT-5041
	2"		GT-5042
	Flexible		GT-9492

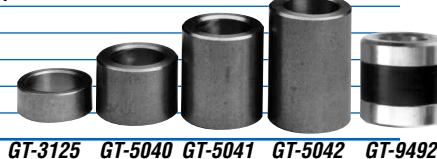
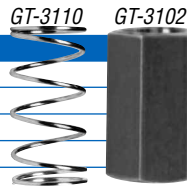

NEW!



Neoprene Brake Lathe Silencer Longer lasting than rubber

- Neoprene material resists deterioration associated with standard rubber belts
- Measures: 34" L x 5/8" W x 3/16" Thick
- 6 weights
- Order No. **GT-6030N**

NEW!

Crack and Leak Repair Additives Stop leaks fast!



Ceramic Motor Seal

- Seals porosity in cooling systems
- Inhibits rust formation and salt water corrosion during normal operation
- 16 fl. oz. / 455 mL

All Weather Seal

- Works in less than 5 minutes • Seal minor cracks and leaks in cooling system
- Fast acting • Non-corrosive
- Non-clogging • Can be used with coolant or anti-freeze
- 16 fl. oz. / 455 mL

Engine Seal Tabs

- Use on water leaks in heads, blocks, radiators, water pumps, heater cores, manifolds, etc. • 3 1/2 gram tablets treat up to 9 quart cooling system
- 20 tabs per pack



Description	Order No.
Ceramic Motor Seal	CRS-16
All Weather Seal	AWS-16
Engine Seal Tabs (20 pack)	EST-10



Q: How can I tell if my arbor is bent? It looks okay, but I'd like to check it. What do I do?

A: A fast, but costly way to tell if you have a bent arbor is to check a rotor you've just machined. If it has more run-out than it did before you started, you have a bent arbor. We recommend checking the arbor using a dial indicator on a regular basis. Take three readings – one at the end of the arbor, one in the middle and one close to the lathe. If there's more than .001" difference, it's time to replace the arbor with a new one. Be sure to replace the arbor nut at the same time to prevent premature wear on the arbor threads. Performing this simple test on a regular basis will save you the time and money of re-cutting rotors because the arbor was bent.

For more information, visit <http://www.goodtool-online.com/tech/arbor.php>

Go from this ...

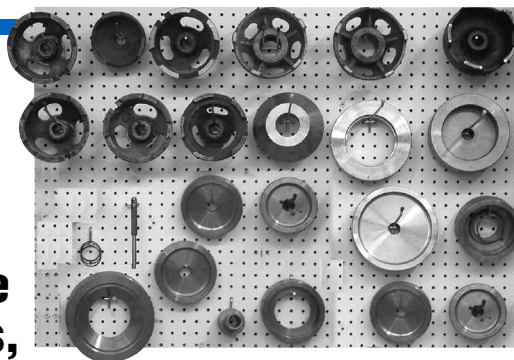

Quick Chuck Adaptor

Replace a whole wall of adaptors, centering cones, spacers, etc. with this easy to use system

- Eliminates mounting problems with the unique self-centering feature
- Fits hubless rotors and drums, composite rotors and drums
- Fits most foreign and domestic rotors, drums and flywheels, including light trucks with a centering hole from 2 1/8" to 5 3/4"
- Fits all popular 1" arbor brake lathes

Description	Range	Order No.	Includes
Automotive Chuck Adaptor Kit	2 1/8" to 3 3/4"	GT-70040	
Truck Chuck Adaptor Kit	2 1/8" to 5 3/4"	GT-74160	
Replacement Automotive Jaws	2 1/8" to 3 3/4"	GT-70045	
Large Jaw Set	3 3/4" to 5 3/4"	GT-70041	x
Quick Chuck Adaptor w/Jaws		GT-70042	x x
Standard Backing Plate, 5.2" OD		GT-70043	x x
Chuck Key		GT-70044	x x
Truck Plate (7 1/4" OD)		GT-70046	x
Small Automotive Plate (4 1/4" OD)		GT-70047	
Toyota Plate (6 1/4" OD)		GT-70054	

Visit www.goodtool-online.com/tech to see how easy it is to install the Quick Chuck

to this

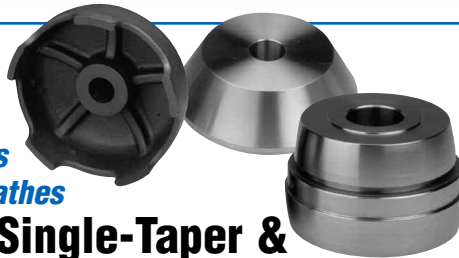
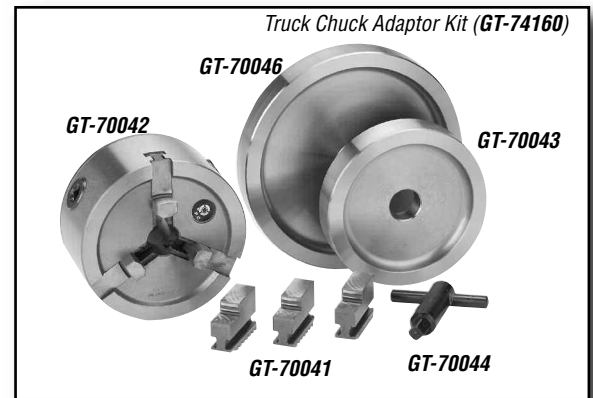

Automotive Adaptors for 1" Arbor Brake Lathes

Bell Clamps, Single-Taper & Double-Taper Centering Cones

Goodtool Master Tooling Set	Order No.	Includes
15 Piece Set	GT-4346	
Automotive Bell Clamps for 1" Arbors		
OD Size		
3.625"	GT-9489	x
4.500"	GT-9490	x
5.750"	GT-3123	x
Single-Tapered Centering Cones for 1" Arbors		
7-Piece Set	GT-3777	
Range		
1.250" - 1.750"	GT-3902	x x
1.187" - 2.250"	GT-3903	x x
1.703" - 2.750"	GT-3904	x x
2.328" - 2.986"	GT-3108	x x
2.650" - 3.224"	GT-3178	x x
2.890" - 3.500"	GT-3107	x x
3.421" - 4.031"	GT-3106	x x
Double-Tapered Centering Cones for 1" Arbors		
2 Piece Set	GT-9233	
5 Piece Set	GT-9232	
Range		
1.322" - 1.670"	GT-9921	x x
1.362" - 1.710"	GT-9922	x x
1.711" - 2.073"	GT-9192	x x
2.074" - 2.440"	GT-9193	x x
2.441" - 2.897"	GT-9194	x x
2.828" - 3.185"	GT-9195	x
3.203" - 3.560"	GT-9196	x

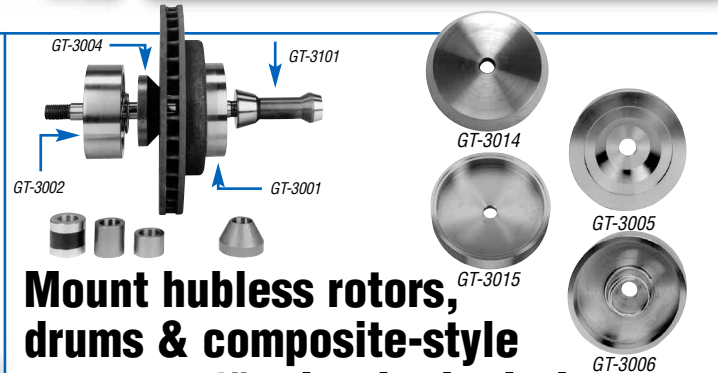

Mount hubless rotors, drums & composite-style rotors to 1" arbor brake lathes

- All parts made of pre-hardened, alloy steel to resist nicks and dents
- Fewer pieces means a lower price (about half of other sets with similar capabilities)

Mounting Sets	Order No.	Includes
Complete Set	GT-3010	
Hubless Rotor & Drum Set		
	GT-3000	
One-Ton Composite Rotor Set		
Centering Cones		
1.187" to 2.250"	GT-3003	x x
2.032" to 3.975"	GT-3004	x x
5.875" to 7.375"	GT-3014	
6.875" to 8.125"	GT-3016	
Front Cup with Spring		
4" dia.	GT-3009	
5 1/4" dia.	GT-3002	x x
7" dia.	GT-3006	x x
Spacers		
1" long	GT-5040	x x
1 1/2" long	GT-5041	x x
Self-aligning	GT-9492	x x
Backing Plates		
5.25"	GT-3001	x x
7.00"	GT-3005	x x
7.550"	GT-3007	
8.375"	GT-3015	

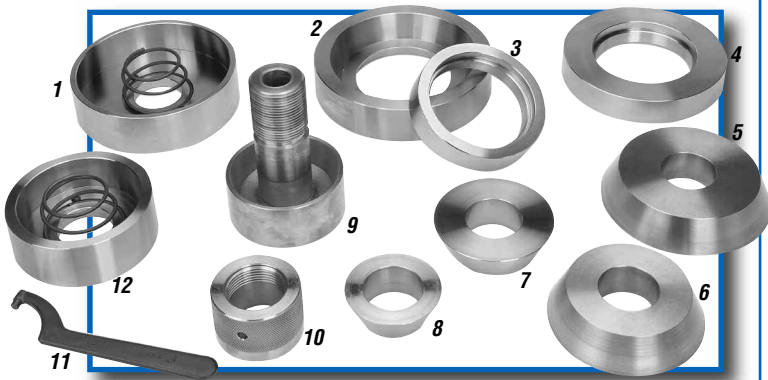

**Universal Adaptor
Plus Mounting System**

**Use fewer
adaptors to
mount a wider
range of hubless
drums & rotors**

- Mount hubless drums, rotors and composite rotors to 1" arbors
- Cones center workpieces with holes 2 3/32" to 6 1/4"

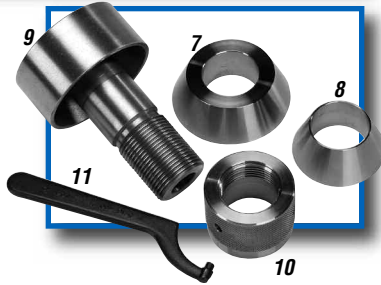

Description	Order No.	Includes
Master Adaptor Plus Mounting Kit	AP-9000	
Truck Drum Kit (must use with AP-4700)	AP-5000	
Hubless Locator Assembly	AP-4700	
1 Large Adaptor Cup with Spring (6.75" OD)	AP-1039	x
2 Large Backing Plate (6.75" OD)	AP-1035	x
3 Small Backing Plate (5.25" OD)	AP-1036	x
4 Truck Backing Plate (7.40" OD)	AP-1037	x x
5 Truck Centering Cone (5.125" x 6.250")	AP-1040B	x x
6 Truck Centering Cone (4.125" x 5.250")	AP-1040A	x x
7 Hubless Adaptor Cone (3.125" x 4.25")	AP-1003B	x x
8 Hubless Adaptor Cone (2.125" x 3.25")	AP-1003A	x x
9 Locator for 1" Arbor	AP-1001	x x
10 Nut & Spacer	AP-1009	x
11 Spanner Wrench	HA-800W	x x
12 Small Adaptor Cup with Spring (5.25" OD)	AP-1038	x

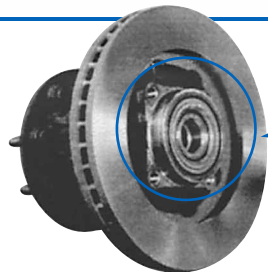

GT-29495

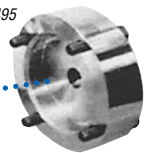

For GM 4x4 ('92 & later),
Dodge Ram ('94 & later)
Ford 1-ton ('98 & later)



Late Model Rotor Adaptor
**Turn late model 3/4 &
1-ton rotor assemblies
without disassembly**

- Locates from the rear bearing flange • Mounts to any 1" arbor brake lathe • One-piece adaptor with four bolts

Description	Order No.
Rotor Adaptor	GT-29495
Replacement Bolt Set (4 Pc.)	GT-29495-SET

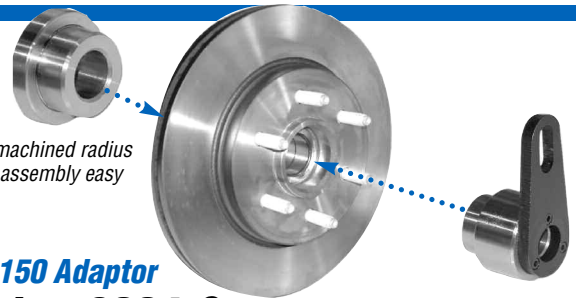

Large machined radius
makes assembly easy

Ford F-150 Adaptor
**Machine 2004 & newer
Ford F-150 2WD rotors
without removing the bearings**

- Fast, simple setup means less time spent on mounting the rotor on your lathe • Designed by a technician and proven to fit rotors with pressed in bearings • Two piece kit includes outboard centering drive adaptor and rear centering adaptor
- Approved for late model Ford F-150 two-wheel drive applications with pressed in bearings

Description	Order No.
Ford F-150 Rotor Adaptor	FRA-5532
1 3/4" dia. 180 Grit Flex-Hone®	BH-1750

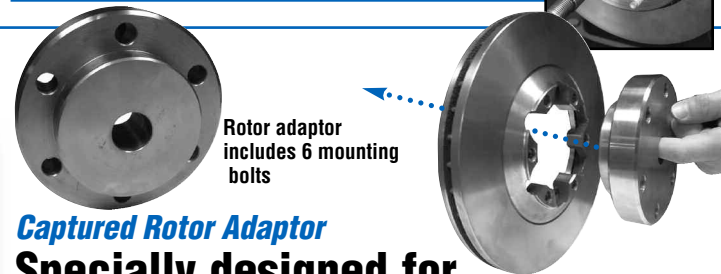

Rotor adaptor
includes 6 mounting
bolts

Captured Rotor Adaptor
**Specially designed for
2004 & later Chevy Colorado &
GMC Canyon models**

This one-piece rotor adaptor is self-centering and is compatible with all 1" arbor lathes. Unlike most adaptors, you must mount this set-up with the adaptor and machined side of the rotor toward the lathe. This will allow the twin cutter to align properly. The adaptor includes 6 mounting bolts. Order No. **CRA-2004**



For 1" Arbors
Truck Adaptor Sets

Description	Order No.	Includes
Standard Truck Set	GT-5062	
Master Truck Set	GT-5060	
Centering Cones 3.750" x 5.125"	GT-5053	1 1
4.500" x 5.500"	GT-5052	
5.000" x 6.125"	GT-5054	1
Bell Clamps 6.500" OD	GT-5055	1 2
7.750" OD	GT-5056	1
Heavy-duty Spring	GT-5059	1 1

AMMCO Brake Lathe Replacement Parts

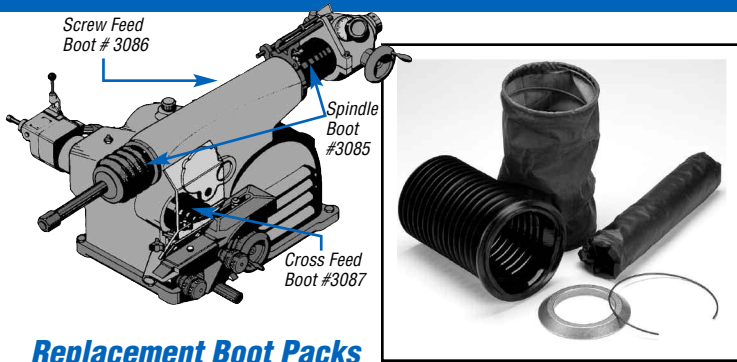

Replacement Boot Packs

Keep extra boots on hand for routine maintenance or emergency replacement!

Fits Ammco 3000, 4000, 4100, 7000, 7700

Description	Order No.	Incl.		
Neoprene Boot Pack	GT-BOOT-PK			
Rubber Boot Pack	RSB-BOOT-PK			
Neoprene Spindle Boot Kit	SBR-KIT			
Rubber Spindle Boot Kit	RSB-KIT			
Rubber Spindle Boot	RSB-3085	x	x	
Neoprene Spindle Boot	3085	x	x	x
Screw Feed Dust Boot	3086	x	x	x
Cross Feed Dust Boot	3087	x	x	x
Boot Ring	23682	x	x	x
C-Clip	SBR-4435	x	x	x
Snap Ring	SBR-3159	x	x	x

Replacement Parts Pack

Save on replacement parts with this convenient parts pack

- **Save time** - never be caught without one of these essential brake lathe replacement parts again
- **Save money** - pack price is 10% lower than ordering all parts separately
- **Save on shipping** - purchasing these parts together costs less in shipping than ordering them individually at different times. You pay shipping and handling one time instead of several!
- All parts are also sold separately



Description	Order No.	Incl.
Replacement Parts Pack	GT-PARTS-PK	
Cross Feed Shear Gear	7996	2
Replacement Locking Knob	6854	2
Feed Seal	3163	1
Spindle Seal	3164	1
Neoprene Spindle Boot	3085	1
Screw Feed Dust Boot	3086	1
Cross Feed Dust Boot	3087	1

Tool Bit Holders for 6900 & 6950 Twin Cutters

Left-Hand
Order No. 10650
Right-Hand
Order No. 10651

Replacement Screw
Order No. GT-9249



Brass Wear Inserts

3/16" x 1/8"
Order No. GT-3141
1 9/64" x 1/4" (most popular)
Order No. GT-3142
1/4" x 1 9/64"
Order No. GT-9836



Cross Feed Shear Gear for 4000, 4100

Includes C-Clip
Order No. 7996



Replacement Red Locking Knob

Order No. 6854



Rotor Bearing Protector

Fits arbor up to 2 1/4"
Order No. 4282



Seals

Feed Screw Spindle
Order No. 3163
Order No. 3164

Buy 5 or more (mix or match 7996 & 6854) save 10%

Work Light

Fits Ammco lathes

- 30" arm • 5/8" round mounting end
- Adjustable arm allows you to position light right where needed
- Uses up to 100W standard bulb (not included)
- Easily accessible on/off switch
- Other shop applications as well
- Order No. GT-7963



Chip Shield & Twin Cutter for Ammco

Includes Double Duty Holders and cutting tips

- Fits Ammco 4000, 7000 & 3850

Description	Order No.	Incl.
Chip Shield & Bracket	GT-9481	
Twin Cutter (Replaces obsolete 6900)	6950	
Double Duty Cutting Tip Holder - Left	DTAM-312L	1
Double Duty Cutting Tip Holder - Right	DTAM-312R	1



NEW!
Lower Price



1HP Replacement Motor

- Fits 3000, 4000, 4100, 7000, 7500, & 7700 models
- 208/230/115V
- 1725 RPM • 60Hz
- Order No. **GT-2165**



Right Angle Drive Assembly

- Fits 3000 & 4000 lathes
- Eliminates radial & axial play
- Order No. **GT-9815**

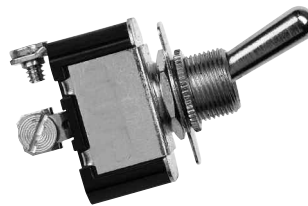

Replacement Switch

- Easy to install
- Fits most models
- Order No. **GT-7893**

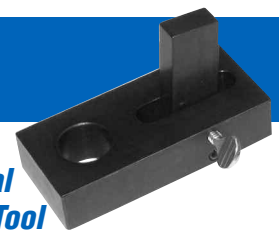

Special Drive Tool

- No need to remove pressed-in bearings • Works on most rotors and drums with pressed-in bearings • Drives rotors and drums using the lug bolts • Fits any lathe with a 1" arbor
- Order No. **GT-5021**

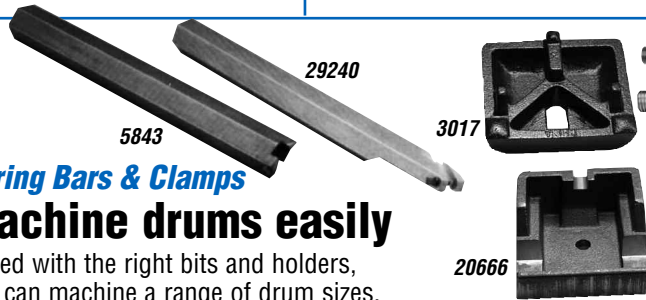

Boring Bars & Clamps Machine drums easily

Paired with the right bits and holders, you can machine a range of drum sizes.

Description	Fits Ammco Model(s)	Order No.
1½" hex X 15½"	3000, 4000	5843
1½" hex X 19½"	4100,4000,3000	5844
1½" hex X 16½"	3850	29240
Upper Clamp		3017
Lower Clamp		20666



Ammco Rotor & Drum Feed Screws & Nuts

Description	Order No.
Rotor Feed Nut (early)	GT-10868
Rotor Feed Nut (late)	GT-10868X
Drum Feed Nut (all)	GT-4670
Rotor Feed Screw (4000)	GT-32111
Rotor Feed Screw (7000)	GT-10318
Lead Drum Feed Screw (3000, 4000)	GT-9918

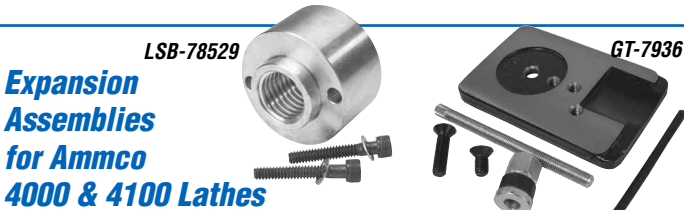

Expansion Assemblies for Ammco 4000 & 4100 Lathes

Expand the capacity of your lathe up to 17¹⁵/₁₆" diameter rotors

Description	Max. Dia.	Application	Order No.	Incl.
Lathe Expansion Set			GT-7935	▼
Lead Screw Bushing	15"	SUVs, Pick-ups	LSB-78529	x
Cross Feed Extension	17 ¹⁵ / ₁₆ "	1-ton + Trucks	GT-7936	x
Lower Guide Bar (extends range by 1½")	19¼" L		GT-70346	x
OEM Cross Feed Extension	17 ¹⁵ / ₁₆ "	1-ton + Trucks	6936	



Install the drive pulley with the pin toward the right angle drive. The two roll-pins drive against each other. A nylon sleeve prevents metal to metal contact.



Drive Pulleys & Belts Increase speed with serpentine style belts

- Fit Ammco 3000, 4000, 4100, 7000 & 7100
- Serpentine design runs quieter and increases arbor speed by 175RPMs • Virtually eliminates vibration

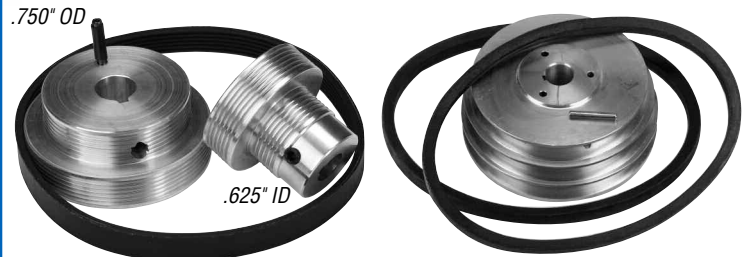

New-Style (Serpentine)

Description	Order No.
Pulley Set (Includes 20¼" belt & 2 pulleys)	GT-5001
20¼" Belt	GT-5002
19" Belt	GT-5003

Original-Style (V-belt)

Description	Order No.
Drive (Motor) Pulley	GT-3024
Driven (Arbor) Pulley	GT-7784-1
25" (replaces 3161)	GT-3161
24" (replaces 10241)	GT-10241



Tooling Hold Down Pieces

Description	Order No.	Incl.
Stud Assembly	GT-25900	▼
6½" Stud	GT-25913	x
Nut Assembly*must be used with 6½" Stud	GT-11227	x
5½" Stud	GT-3031	
Washers (2)	GT-3165	

Replacement Parts for Accu-Turn, FMC & Bean

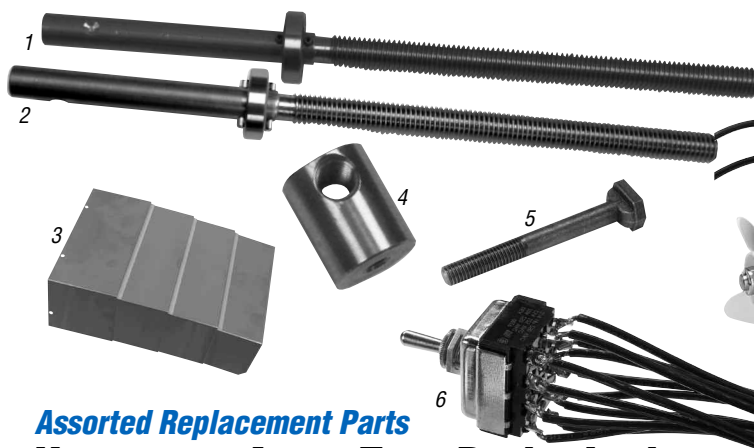

Assorted Replacement Parts Keep your Accu-Turn Brake Lathe running in tip-top shape

Description	Order No.
1 Rotor Feed Screw Assembly (1/2" 20TPI)	GT-433156
2 Drum Feed Screw Assembly (1/2" 13TPI)	GT-433157
3 Telescoping Way Assembly (fits all except 8989)	GT-433735
4 Rotor Feed Nut	GT-433647
5 T-Bolt	GT-433633
6 Drum Feed Nut (not shown)	GT-433646
6 Replacement Switch	GT-3693

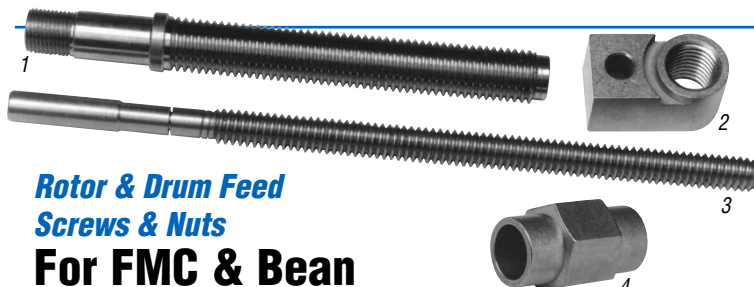

Rotor & Drum Feed Screws & Nuts For FMC & Bean

Description	Order No.
1 Rotor Feed Screw	GT-90071
2 Rotor Feed Nut	GT-90077
3 Drum Feed Screw	GT-90667
4 Drum Feed Nut	GT-1016845

Heavy Duty XLT PowerBleeder™ Single person use! No additional equipment required

- Uses pressurized brake fluid to force air and contamination out
- No need for an air compressor
- Use PowerBleeder™ anywhere - the shop, the track, the home Capacity: 4 quart
- Adaptors Included: European, Metal Round Universal, Metal Rectangular Universal, Chrysler/Dodge, Ford 3-Tab, GM/Ford 3-Tab • Tubing: 6 feet • Connector: Quick Release
- Order No. **GT-390**



Many more
online!

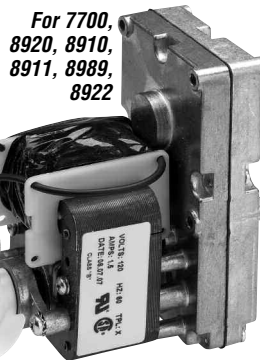

Replacement Feed Motor For Accu-Turn Brake Lathes

- 1/60 HP • 6 RPM • 120V, 60Hz
- 1.5 Amps • Includes fan
- 2 year limited manufacturer's warranty • Ships without blade attached to prevent damage
- Order No. **GT-3641** []

Variable Speed Replacement Feed Motor

For Accu-Turn 8944 & VN V-22 Brake Lathes

- 90 Volt DC Permanent Magnet Gear Motor
- 1/3 HP • RPM F/L: 21 • Torque F/L: 50 in-lbs.
- Ratio: 16:1 • Mounting: Face • 5/16" diameter shaft
- Continuous duty • Sleeve bearings in motor and gearbox
- 2 year limited manufacturer's warranty
- Order No. **GT-6116**



Brake Shoe Grinding Sleeves

Dia.	Lgth.	Grit	Application	Order No.
3"	3"	100	Fits most models	AS-1
3"	5 1/4"	40	Fits most models	AS-2
3"	6"	40	Fits most models	AS-3
3"	6 5/8"	40	Fits most models	AS-4
3"	7 1/2"	40	Fits most models	AS-6
2 7/8"	4 1/2"	50	Fits Ammco 2007	AS-7
2 7/8"	4 1/2"	24	Fits Ammco	AS-7C
4"	6"	24	Shepard-Thompson	AS-8
4"	8 1/4"	40	Shepard-Thompson	AS-10
3"	4 1/2"	50	Star	AS-11



Brake Drum Swedge Cutting Tool Remove and replace pressed-in wheel studs

- Hard-to-find tool cuts wheel stud swedges to remove and replace pressed-in wheel studs
- Carbide tipped • Use with a drill press or mill

Stud Size	Order No.
7/16"	ST-437
1/2"	ST-500
9/16"	ST-562

Buy all three and get 10% off



MAXXEON®
WorkStar™ 220
Compact Inspection Light
All the brilliance
of a full-size
inspection light in a compact size



- 6" long • 20 times brighter than ordinary pen lights
- Tough anodized black T6 Aluminum body
- Rugged push-button switch is rated at 100,000 cycles
- Will run about 4 hours on 3-AAAA alkaline batteries (included)
- Order No. **DFL-220**



MAXXEON® WorkStar™
Rechargeable LED Worklight

Magnets attach it to most ferrous surfaces

- Head rotates 350° and tilts 180° • Operates over 5 hours with rechargeable batteries (8 AA NiMH, included)
- Can be recharged while in use (charger included)
- Includes a convenient retractable hook to put light where you want it • OAL: 10⁵/₈" • 60 Lumens
- Body: 7"x2 x1³/₄" • Head: 3" x 1¹/₂" x 1¹/₂"
- Light floods the work surface
- Order No. **DFL-1200**

MAXXEON® WorkStar™
Flexible LED
Inspection Light
20 times more
light than
ordinary LEDs



Batteries included!

- 10" gooseneck flexes to avoid obstructions in tight places
- OAL: 18" • Head Diameter: 1¹/₁₆" • Body Diameter: 1³/₁₆"
- Will run about 1.5 hours on 2-AA alkaline batteries
- Order No. **DFL-440**



Ruff-Light

Drop it, step on it,
it keeps on working

- Built to withstand drops and bumps • Patented rough-service fluorescent bulb • 25' cord • Heavy-duty swivel hook
- Fully enclosed safety switch

Description	Order No.
Ruff-Light	BL-25
13W Replacement Bulb	BL-RB



Buy a case of 12
(any combination),
SAVE 10%

Ceramlub rated up to 2800°F

Pastelub rated from -300°F to 2400°F

Brake Lubes

Reduce brake noise and wear with these high quality sprays and lubes

These synthetic lubricants will make your brake jobs easier and your customers happier. Silencer™ Brake Spray is the backbone of this trio. The revolutionary metalizing treatment is OE approved and is effective from -100°F to +2000°F. Ceramlub-2800™ contains ceramic pressure solids and anti-corrosive agents. It is specially designed for use on caliper slides, rubber seals and O-Rings. Pastelub™ is OE recommended and won't melt, rub or wash off brake parts. It contains no silicone or petroleum. It is recommended for use on the back of brake pads.

Description	Order No.	Incl.
Brake Lube TRI-PAK	TMPK-3	▼
Silencer™ Brake Spray	BS-12	1
Ceramlub-2800™ Synthetic Lubricant	CBL-2800	1
Pastelub™ Hi-Temp Lubricant	BPL-2400	1

MIX OR MATCH TO MAKE A CASE OF 12

Flex-hones®

Eliminate set-up time

- Silicon-carbide globules laminated to high density nylon
- Use with liberal amounts of Honing Oil (see web for details)

Silicone-Carbide - 180 Grit

Size	Order No.
1/2"	13mm VGF-13MM
5/8"	16mm BH-625
3/4"	19mm BH-750
13/16"	21mm BH-820
7/8"	22mm BH-875
1"	25mm BH-1000
1 1/8"	29mm BH-1125
1 3/8"	35mm BH-1375
1 1/2"	38mm BCF-150
1 3/4"	45mm BCF-175
2 1/8"	54mm BCF-2125
2 1/2"	64mm BCF-250
2 3/4"	70mm BCF-275
3 1/8"	79mm BCF-3125



Brake Rotor Flex-hones®

For non-directional finish

- Use with a 3/8" variable speed drill at 600-1000 RPM • Use dry • Zirconium abrasive

Type	Grit	Order No.
Fine	240	BRF-25F
Medium	120	BRF-25M
Coarse	60	BRF-25C



Drum & Rotor Measuring Tools



Electronic Digital Gauges

Measure rotors & drums before turning or replacing

Range	Graduations	Arm Length	Order No.
0" - 5.5"	.0005" / .01mm	3.50"	EDB-430
6" - 20.5"	.001" / .01mm	4.25"	EDB-530
Replacement Batteries			EDC-06B

Drum Micrometer

Measure drums on or off the lathe

- Easy-to-read dial • .005" graduations
- Also use to check for roundness

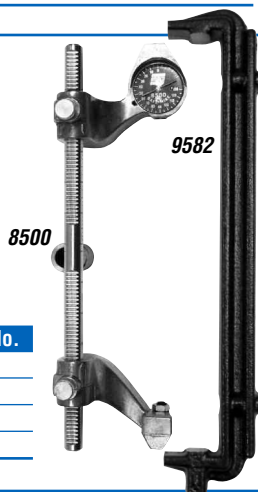

Description	Order No.
Micrometer (6" to 16 1/8")	8500
Checking Gauge	9582
Extension Shaft (6" to 26")	8539
Rebuild Kit	9935

Economy Micrometers

.0001" graduations

- Precision ground carbide anvil parallel to within .00005"

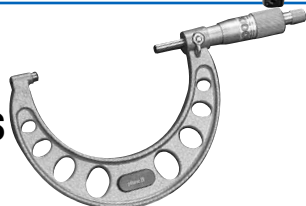

Description	Range	Order No.	Incl.
Economy Micrometer Set		EMS-06	▼
Individual Micrometers	0"-1"	EMIC-01	x
	1"-2"	EMIC-12	x
Each micrometer	2"-3"	EMIC-23	x
includes a standard,	3"-4"	EMIC-34	x
spanner wrench & case	4"-5"	EMIC-45	x
	5"-6"	EMIC-56	x



Calipers

Accurate to .001"

Dial Caliper	Range	Revolutions	Accuracy	Order No.
	0-12"	.100" per	.001"	EDC-12
Digital Caliper	Range	Graduations		Order No.
	0-6"	.001"		EDC-301

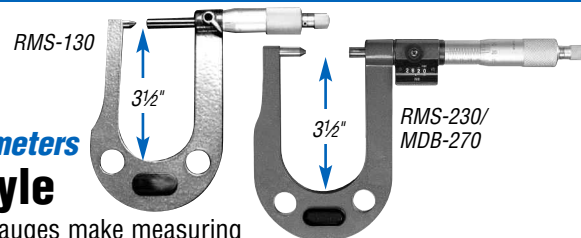

Rotor Micrometers Swiss-style

- Easy to read gauges make measuring rotors simple and accurate
- Pointed anvils get into the grooves of the rotor for accurate measurements
- Case included

Scale	Range	Grad.	Order No.
US Standard Mechanical	.300"-1.300"	.0001"	RMS-130
US Standard Mechanical Digital	.300"-1.300"	.0001"	RMS-230
Metric Mechanical Digital	7-33mm	.001mm	MDB-270

Disc Rotor & Ball Joint Gauges

Measure rotor runout or ball joint wear

- Flexible arm can be locked into almost any position
- Unit includes: flexible arm, dial indicator (0"-1"), curved jaw locking pliers and case

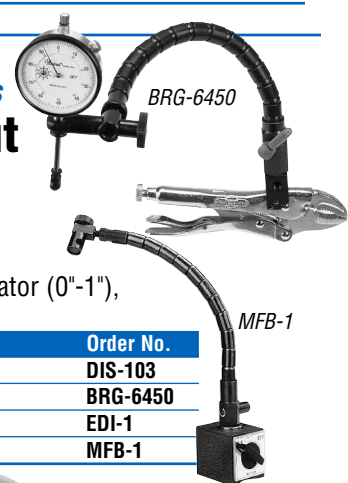

Description	Order No.
Economy Disc Rotor & Ball Joint Gauge	DIS-103
Central® Disc Rotor & Ball Joint Gauge	BRG-6450
Replacement Dial Indicator	EDI-1
Flexible Arm Dial Indicator Magnetic Stand	MFB-1

Standard



Gauntlet

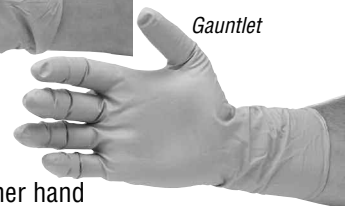

Unlined Nitrile Gloves

Use with solvents, cleaners, oils, etc.

- Industrial quality textured Nitrile • Fit either hand

	Size	Qty.	Order No.
Standard (9" long)	Large	100	NGL-L
	X-Large	100	NGL-XL
Gauntlet (12" long)	Large	50	PNG-L
	X-Large	50	PNG-XL

Find more cleaning and safety products at www.goodtool-online.com



24" Kevlar® Knit Sleeve

Protect yourself from minor scrapes and burns

- Manufactured in 2 ply x 3" wide x 24" long Kevlar® material
- Lightweight and non-irritating • Will NOT support combustion
- Thumb-hole to prevent riding up • Elastic binding prevents slipping
- Wash or dry clean • Order No. **KAS-24**

Alignment Tools & Supplies



**Buy 2
Wheel Clamps,
save 10%**

**Buy 4
Wheel Clamps,
save 15%**

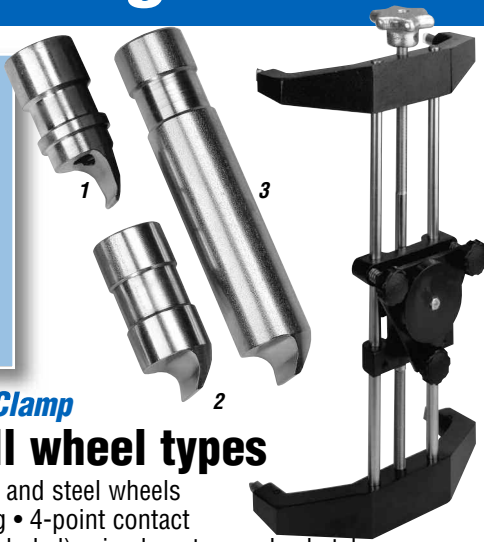

Universal Wheel Clamp

Works on all wheel types

- Adapts to aluminum and steel wheels
- Screw type clamping • 4-point contact
- Hunter style feet (included) grip almost any wheel style
- Replacement feet for additional applications sold separately (see chart below) • 4 required for clamp

Application	Rim Size	Order No.
Automotive (1)	10" - 19"	GT-8069
Truck (1)	16" - 26"	GT-8070
Replacement Feet	Qty. Per Pack	
1 Aluminum for Rimless Wheels	4	GT-522-4
	1	GT-522
2 Aluminum Wheels	4	GT-562-4
	1	GT-562
3 Extended for Dual Rear Wheels	4	GT-562-EXT-4
	1	GT-562-EXT

Fits all but Truline - call for more information

3.15" / 80mm diameter magnet



Intercomp

Caster/Camber Bubble Gauge with Magnetic Adaptor

Magnetic adaptor holds gauge for hands-free operation

- CNC-machined aluminum housing
- Easy-to-read bubble display with popular magnetic adaptor
- Measures $\pm 6^\circ$ of camber and $\pm 8^\circ$ of caster with 0.2° accuracy
- Comes in plastic molded case for safe storage
- Order No. **GAT-102010**



"MAGNA CAM" Bolt Kits

Adjust camber on a wide range of vehicles

The fast and easy alternative to adjust camber on vehicles using a standard 2-bolt (upper and lower) strut-to-knuckle mounting bolt design. This design incorporates an offset internal sleeve working in conjunction with a full-size, high-strength OE-diameter bolt (with matching internal offset) which allows camber to be increased or decreased by a simple turn of the bolt. Allows you to accurately adjust camber with weight of the vehicle on the front wheels.

Size	Applications	Order No.
12mm, 12.9	Chevy, Oldsmobile, Pontiac	41-144
	Ford, Hyundai, Mazda	41-146
	Chevy, Dodge, Eagle, Ford, Geo, Hyundai, Isuzu, Mazda, Mercury, Mitsubishi, Nissan, Plymouth, Pontiac, Porsche, SAAB, Subaru, Toyota & Volkswagen	41-147
15mm, 10.9	Geo, Lexus, Toyota	41-149
17mm, 10.9	Lexus, Toyota	41-151
14mm, 12.9	Chrysler, Dodge, Plymouth	41-157
	Buick, Chevy, Infiniti, Oldsmobile, Pontiac, Saturn, Subaru & Volvo	41-158
16mm, 10.9	Acura, Chrysler, Mitsubishi & Honda,	41-159
16mm, 10.9	Buick, Cadillac, Chevy, Chrysler, Dodge, Eagle, Oldsmobile & Pontiac	41-160

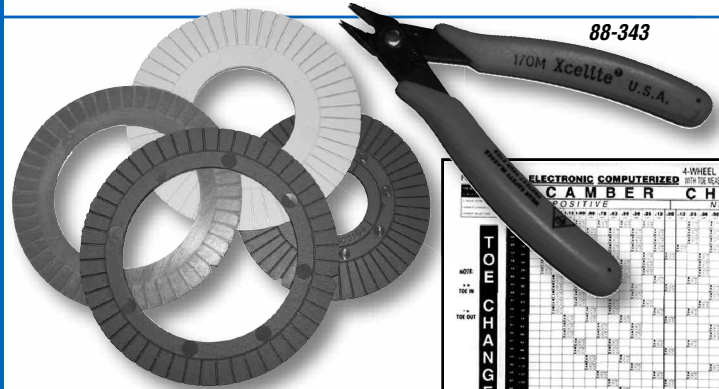

88-343

Rear Full Contact Shim Assortment

46-1030

Complete Master Kit for adjusting rear camber and toe

- Includes 72 assorted Shims, Application Chart, Paint Stick, Instructions and Cutting Tool
- Covers virtually all makes and models
- Adjustment ranges from .25° to 1.5° on selected models
- Shims also sold separately • Visit www.goodtool-online.com or call 1-800-880-7121 for shim numbers and applications

Description	Order No.
Master Shim Kit	46-5004A
Shim Template Assortment (8 pc.)	46-4000A
Coated Shim Indexing Wall Chart	46-1030
Paint Stick	46-1035
Cutting Tool	88-343

Differential Pinion Shaft Kit

Remove broken pins from GM & Ford vehicles in minutes

- Screw in drill bushing, drill hole, use bolt extractor to remove broken pins

Description	Order No.
Complete Kit	DKW-5
Replacement Drill Bit	DKW-1



Caster/Camber Adjustment Bushings

Easy to adjust Hex-Head bushings

- Adjust camber/caster to a combination of both from .25° to 3.5° either positive or negative
- Not for E250/35 models with modified chassis/suspension
- 1 bushing per package

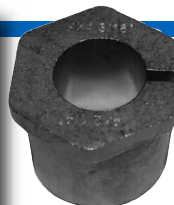
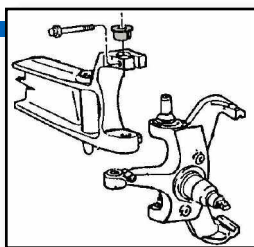

Caster/Camber Bushing Assortment

- Contains 2 of each bushings at left
- Order No. 42-950A

Adjustment		Order No.
2WD	4WD	
0°	0°	FA-42949
.25°	.25°	FA-42951
.5°	.375°	FA-42952
.75°	.5°	FA-42953
1.0°	.75°	FA-42954
1.25°	.875°	FA-42955

Adjustment		Order No.
2WD	4WD	
1.5°	1.0°	FA-42956
1.75°	1.25°	FA-42957
2.0°	1.5°	FA-42958
2.25°	1.75°	FA-42959
2.5°	2.0°	FA-42960

Applications:

1990-94 Explorer	1990-97 Ranger
1991-94 Navajo	1994-99 Mazda Pickup
1989-90 Bronco II	1987-96 F150, F250 & F350
1992-08 Econoline Van	1997-08 Ford Superduty
2000-05 Excursion 2WD	



Ford Light Truck Camber/Caster Cam Bolt Kit

Replaces non-adjustable factory system

- Adjustment range: ±2.5° • 2 per package
- Adjusts one side • Fits 1997-2003 Ford F-150 and 1997-2002 Expedition & Lincoln Navigator
- Order No. FA-42778

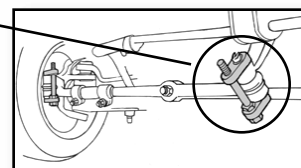

Tie Rod Stabilizer Set

Centers tie rods in their sockets when setting toe

Helps to obtain a straight steering wheel to ensure proper steering performance and maximum tire life. Order No. 88-7205



Many More Alignment Tools & Supplies are Available at www.goodtool-online.com

We don't have enough room in this catalog to include all of the alignment tools you can get from Goodtool. We've included some of the most popular items here but if you don't see what you're looking for, visit www.goodtool-online.com/alignment



Metal Markers

7 colors to choose from

- No shaking required • Quick drying
- Withstands oil, grease and surface contact • Won't lose its brilliance or legibility over time

Color	Order No.
Orange	MM-STD
Black	MM-010
Yellow	MM-030
White	MM-050
Green	MM-060
Red	MM-070
Blue	MM-080

Complete orders ship same day

We ship items by UPS or FedEx Ground. If you need your order in a hurry ask about express shipping. Some of Goodtool's smaller items can also ship via US Postal Service to save you shipping costs.

Easy Ordering by phone, fax or online

To talk to a customer service representative, call us toll-free 1-800-880-7121 anywhere in the United States or Canada. Outside of the US & Canada, call 1-507-454-1454. You can also FAX your order to 1-507-454-1471, or place a secure order online at: www.goodtool-online.com.

Iron-clad Satisfaction Guarantee

We won't risk losing your business for any reason. So if any of our products aren't completely satisfactory, we want you to send it back. Simply note the reason for the return on the original invoice, pack it in the box with the item you're returning and ship it back to us, freight pre-paid, within 30 days. We'll fix it, exchange it, or credit your account. The only time we can't honor the **Iron-Clad Guarantee** is if you've damaged the product by improper use or have modified it to change its function.



Technical Support

Goodtool has several ASE-Certified Technicians on staff to help you use your equipment and our products more effectively. Technical Service Representatives are available Monday through Friday from 8:00 am to 5:00 pm (Central time) or you can email your questions to tech@goodtool-online.com.

Ordering is easy ... just say charge it!

Avoid C.O.D. charges and UPS or FedEx delivery delays by using a credit card, **OR** to set up a **Goodtool Open Credit Account**, call 1-800-880-7121 and request a credit application.



Privacy Policy

All information that Goodtool collects from its customers through purchases, credit applications or other transactions is kept private and is not disclosed to anyone except as permitted by law. Goodtool will not sell this information to anyone. Goodtool will limit employees' access to any customer's non-public information to only those employees who need to know the information to provide products and services to you. Goodtool maintains internal safeguards to protect our customer's non-public information.

©2011, Goodtool Brake Service Tools & Supplies. All copy and illustrations are copyrighted. Absolutely no mechanical or electronic reproduction or use of any part is allowed without prior written approval from Goodtool. Goodtool is an affiliate of Goodson Mfg. Company, Inc., Winona, Minnesota. Prices are subject to change without notice. Goodtool reserves the right to correct printing errors.



Mirrored Safety Glasses

Protect your eyes from debris

- Wrap-around design • Tinted polycarbonate lenses provide sun glare protection
- Universal bridge
- Order No. PGL-21



Magnifying Safety Glasses

Several magnifications available

Diopter	Order No.	Diopter	Order No.
1.00	BSG-100	2.00	BSG-200
1.25	BSG-125	2.25	BSG-225
1.50	BSG-150	2.50	BSG-250
1.75	BSG-175	3.00	BSG-300

Flywheel Grinding Stones



Size	Description	Order No.
CAST IRON (Passenger cars, light trucks)		
3"x2"x1 1/4"	Green silicone-carbide	FGW-93
6"-4 1/2"x2 3/8"x1 1/4"	Best all-around for cast iron, black	FGW-57
6"-4 1/2"x2 3/8"x1 1/4"	Softer than FGW-57, grinds faster, black	FGW-47
6"-4 1/2"x2 3/8"x1 1/4"	Silicone-carbide, ideal for top fuel, black	FGW-37
CAST STEEL (Industrial, agricultural, OTR trucks)		
6"-4 1/2"x2 3/8"x1 1/4"	Best all-around for Cast Steel, speckled	FGW-65
6"-4 1/2"x2 3/8"x1 1/4"	Slightly softer than FGW-65, black	FGW-495
BILLET STEEL (Import vehicles, high-performance)		
6"-4 1/2"x2 3/8"x1 1/4"	Harder, ruby stone, lasts longer	FGW-64
4"-3 1/2"x1 1/2"x1 1/4"	Harder, pink stone, lasts longer	FGW-63-1
4"-3"x2"x1 1/4"	Softer than FGW-50-2, white	FGW-306
6"-4 1/2"x2 3/8"x1 1/4"	Best all-around for Billet Steel	FGW-50-2

Many more flywheel stones are available at www.goodtool-online.com

CBN Flywheel Grinding Wheels

Use with fresh coolant

- Aluminum core
- 1/8" thick CBN material • 1 1/4" arbor



Size	Order No.
2" dia., straight sides	ECBN-200
2 1/4" dia., straight sides	ECBN-225
2 1/2" dia., straight sides	ECBN-250
3" dia., straight sides	ECBN-300
4" dia., flared sides	ECBN-4
6" dia., flared sides	ECBN-6
1 Gallon Flywheel Grinding Coolant	FG-1101-G

High-Performance Hylomar®

Gasket Maker & Thread Sealer



Maintains seal integrity up to 600°F

- Polyol-based compound turns from a gel into flexible putty within minutes of application • Non-hardening formula
- Impervious to oil, gasoline, glycol and other engine fluids
- Oxygen-sensor safe • Seals gaps .01" or less
- 100 gram tube • Order No. HBS-1

Solvent 184 Cleaner/Degreaser

Removes Hylomar®

- Non-flammable • Non-aerosol • Built in nozzle cap reduces waste • 16 oz./473 mL
- Order No. HAS-16



1/2" Composite Wrench

Specifications:	Clutch Twin Mechanism Hammer
Maximum Torque (ft-lb)	1000
Sound Level (dba)	84
Free Speed (RPM)	9500
Air Pressure (PSI)	90
Air Inlet (NPT)	1/4"
Air Consumption (cfm)	4
Net Weight (lbs.)	4.5
Order No.	IW-1000TH



3/8" Composite Wrench

Specifications:	Clutch Twin Mechanism Hammer
Maximum Torque (ft-lb)	400
Sound Level (dba)	85
Free Speed (RPM)	10,000
Air Pressure (PSI)	90
Air Inlet (NPT)	1/4"
Air Consumption (cfm)	4
Net Weight (lbs.)	2.6
Order No.	IW-1300TH

AIRCAT

1/4" Mini Ratchet

Only 82 dB

- Free Speed: 320 RPM • Air Inlet: 1/4"
- Max. Torque: 45 ft-lb • Operating Pressure: 90 PSI • Air Consumption: 3.5 cfm • Sound Pressure: 82 DBA
- Order No. MR-14

AIRCAT

3/8" Air Ratchet

Heavy Duty

- Free Speed: 180 RPM
- Air Inlet: 1/4"
- Max. Torque: 90 ft-lb
- Operating Pressure: 90 PSI
- Air Consumption: 3.5 cfm
- Sound Pressure: 82 DBA
- Order No. AR-38

Dowel Puller & Collets

Slide hammer action removes stubborn dowels

- Ideal for use on flywheels, etc. • Split collets grip without causing damage so you can reuse dowel pins
- Collets available in metric and US standard (4mm to .8000" IDs available)
- More on www.goodtool-online.com

Description	Order No
US Standard Kit (1/4", 5/16", 3/8" & 7/16")	GA-600
Metric Kit (4, 5, 6 & 8 mm)	GA-600M
Slide Shaft	GAO-1
Slide Hammer	GAO-2
Tightening Sleeve	GAO-3



Parts Baskets

Organize, clean and store small parts

- Galvanized welded 1/4" mesh
- Withstands most solvents
- Lids keep parts from falling out
- Not for use in caustics

Description	Dia.	Length	Order No.
Small Basket with Lid	2.25"	7.00"	PWB-2
Medium Basket with Lid	4.50"	7.00"	PWB-4
Large Basket with Lid	8.00"	9.00"	PWB-15

Find more Parts Baskets at www.goodtool-online.com

PWB-15



PWB-4

PWB-2

KEY CODE



ACCOUNT NUMBER



Back by popular demand!

You asked for it and Goodtool has responded by bringing back a wide range of Tire Changing Accessories. A few highlights are listed below, but you can find our full line on our website at: www.goodtool-online.com/TireChanger

Tire Changer Cone For Coats™ Tire Changers

• Order No. GT-108276



Mount / Demount Head For Coats™ Tire Changers

- Nylon Head for Coats® 5000, 6000 & 7000 series rim clamp tire changers • Requires 182767 or 183812 taper end shaft
- Order No. GT-18306



Replacement Inflater Hoses For most popular tire changers

Description	Order No.
Corgi 60"L ¼" Hose, ½ MPT x Euro Coupling	TIH-00012
Corgi 60"L ¼" Hose, MPT x Euro Coupling	TIH-00014
Coats 60"L ¼" Hose, MPT x Euro Coupling	TIH-00015
FMC 52"L ¼" Hose Female Swivel x Euro Coupling w/guard	TIH-00020
Hunter 60"L ¼" Hose ¼" MPT x ¼" MPT	TIH-00025
Euro Coupling for Hunter Hose	TIH-202

More available online at www.goodtool-online.com/TireChanger



Sign up at www.goodtool-online.com to receive product updates, special offers and more by email!

Strip Dip™ Brake Fluid Test Strips

Do more brake jobs by testing brake fluid

- Simple, visual test to determine brake fluid condition
- Easy to read bright colored results
- Provides a recommendation for service and strip can be given to customer for visual proof of contamination • **NOT** a moisture test
- Tests dissolved metal contamination in brake fluid
- 100 test strips per package
- Order No. BF-TS



Super Scraper™

Remove gaskets, carbon, rust, paint, etc.

- Precision-ground • Solid carbide-tipped
- Double-edged blade • Lasts 200 times longer than plain steel • Nickel-chrome
- 1/8" thick steel shank • Works on all metals including aluminum

Width	Order No.
1 1/4"	SS-4U
2"	SS-4U2



order toll-free at 1-800-880-7121